

# Renegade™

STAINLESS STEEL HOPPERS

SNOWEX®

## SPREADING—YOUR WAY.

Based on the material your operation most commonly uses for de-icing, the SnowEx® Renegade line offers the best material delivery system for you.

### HELIXX™ AUGER TECHNOLOGY

Patent-pending corkscrew material delivery system is optimized to operate in the target range for rock salt spreading best practices.

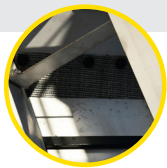

### MATERIAL SPILL PROTECTOR

CHAIN MODELS ONLY

A protection flap at the end of the conveyor prevents material from spilling out and pooling near the vehicle cab.

### RIVETED CONSTRUCTION

Constructed entirely of rivets and bolts, with no welding. Provides a cleaner stainless look and is easier to repair.

### WIRING CHANNEL

Channels on either side of the hopper allow wires and cables to be easily run from the hopper to the cab.



### MATERIAL DELIVERY EXTENSION/ PRE-WET CHAMBER

A material delivery extension reduces leaking/spilling during transport and leads into the patented pre-wet mixing chamber. It also provides a cab-forward design for added stability.

### ACCESSORIES

Expansion Collar | Pre-Wet System with Direct Liquid Capability | Central Point Grease Kit | Spill Guard Kit | LED Work Light Kit | LED Strobe Light Kit | Pullover Tarp Kit (1.5 & 2.2 cu yd models) | Vibrator Kit | Rear View Material Monitoring Camera

### ALL-NEW PINTLE CHAIN CONVEYOR

The large conveyor delivers reliable, smooth, and consistent material flow for heavy, dense materials while reducing bridging.



### REPLACEABLE SCREEN ANCHOR

This piece is now bolted on instead of welded for easy replacement.

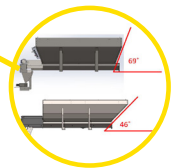

### STEEPER END CAPS

Provides better material flow so more of the hopper load can be spread with each fill.

### COMMON PART CHUTE DESIGN

The ergonomic, hinged design uses common components for all models, making service easy. A direct drive motor offers better torque and reduces servicing.

Renegade™ S150C shown

### OPTIMIZED SPINNER CHANNELS

The ridges on the spinner ensure an even distribution of material throughout the spread arc.





## Renegade™ STAINLESS STEEL HOPPERS

	S150C	S220C	S300C	S400C	S500C	S150A	S220A	S300A	S400A	S500A
Body Side Length	7'	8'	8'	9'	9'	7'	8'	8'	9'	9'
Capacity – Volume	1.5 cu yd	2.2 cu yd	3.0 cu yd	4.0 cu yd	5.0 cu yd	1.5 cu yd	2.2 cu yd	3.0 cu yd	4.0 cu yd	5.0 cu yd
Capacity – Weight*	3,240 lb	4,752 lb	6,480 lb	8,640 lb	10,800 lb	3,240 lb	4,752 lb	6,480 lb	8,640 lb	10,800 lb
Hopper Construction	Riveted Stainless Steel									
Rec. Bed Length	76"	90"	90"	96"	96"	76"	90"	90"	96"	96"
Approx. Weight – Empty	530 lb	580 lb	750 lb	820 lb	910 lb	500 lb	550 lb	700 lb	770 lb	850 lb
Material Delivery System	Pintle Chain Conveyor System					HELIXX™ Auger Technology				
Conveyor Width	16"					N/A				
Conveyor Material	Sand & Salt/Sand Mix					N/A				
HELIXX™ Auger Dimensions	N/A					6" Diameter				
Auger Material	N/A					Bulk Rock Salt				
Spinner Size	16" diameter									
Salt Spread Width	36'									
Sand Spread Width	24'									
Vehicle Application	Pickup		Flatbed/Dump Body			Pickup		Flatbed/Dump Body		

### DIMENSIONS - Refer to the schematics below

A.	Hopper Length	84.50"	96.50"	96.50"	108.50"	108.50"	84.50"	96.50"	96.50"	108.50"	108.50"
B.	Length from Cab Side to Hopper Leg	65.50"	70.50"	82.50"	82.50"	82.50"	62.50"	67.50"	79.50"	79.50"	79.50"
C.	Overall Hopper Length	107.00"	119.25"	120.50"	128.75"	126.25"	111.50"	123.00"	123.00"	129.00"	129.00"
D.	Width of Hopper Opening	50.00"	50.00"	70.00"	70.00"	70.00"	50.00"	50.00"	70.00"	70.00"	70.00"
E.	Height of Hopper w/o Chute	32.00"	35.75"	41.00"	43.75"	50.50"	32.00"	35.75"	41.00"	43.75"	50.50"

\* Material weight equates to approximately 2,160 lb/yd<sup>3</sup> or 80 ft<sup>3</sup> (1 bag rock salt = approx. 1 ft<sup>3</sup>)

**REFERENCE DIAGRAMS**  
reference diagrams show chain models

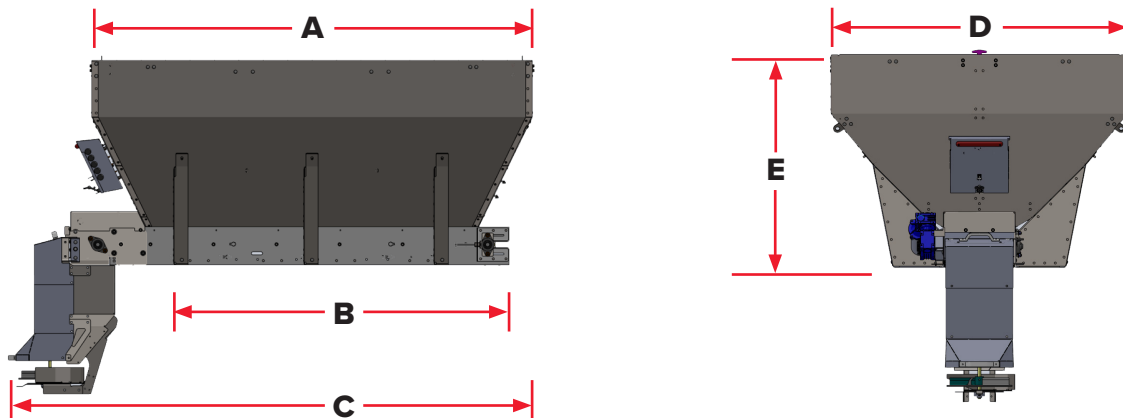

Trynex International LLC | Madison Heights, Michigan 48071

[snowexproducts.com](http://snowexproducts.com)

**2 WINTER WARRANTY**

Trynex International reserves the right under its product improvement policy to change construction or design details and furnish equipment when so altered without reference to illustrations or specifications used. Trynex International or the vehicle manufacturer may require or recommend optional equipment for snow removal. Do not exceed vehicle ratings. This product is manufactured under the following patents US: 7,400,058; 7,481,384; 9,296,571; other patents pending. Trynex International offers a limited warranty for all hopper spreaders and accessories. See separately printed page for this important information. The following are registered (®) or unregistered (™) trademarks of Douglas Dynamics, LLC: HELIXX™, Renegade™, SnowEx®