

ALL-NEW MARAUDER™

POLYETHYLENE HOPPER SPREADERS



RIGHT TOOL FOR THE JOB.

When the snow is flying and temperatures are plummeting, you need to be as efficient as possible. The MARAUDER line of hopper spreaders expands to give you the options you need to maximize efficiency. Corrosion-resistant polyethylene models with your choice of pintle chain or the ALL-NEW HELIXX™ auger delivery system are added to the MARAUDER line for more options to fit your operation's needs.

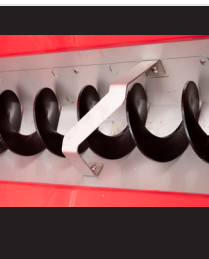

ALL-NEW

HELIXX AUGER TECHNOLOGY

Patented corkscrew material delivery system is optimized to operate in the target range for rock salt spreading best practices.

OR

PINTLE CHAIN CONVEYOR

The large conveyor delivers reliable, smooth, and consistent material flow for heavy, dense materials while reducing bridging.



INTERLOCKING POLY LIDS

Standard lids have molded channels for moisture run-off. Pockets at the end of the lid allow a 2x4 to be inserted for leverage while opening.

POLYETHYLENE CONSTRUCTION

Resist the corrosive environment of de-icing with polyethylene construction. Lightweight, yet highly durable, these hoppers are built to last.

OPTIMIZED SPINNER CHANNELS

The ridges on the spinner ensure an even distribution of material throughout the spread arc.

ADJUSTABLE DEFLECTOR

Adjustable deflector on the spinner is manually positioned left or right to limit spread pattern to protect sensitive surfaces.

MARAUDER™ P220A shown

MATERIAL DELIVERY EXTENSION/ PRE-WET CHAMBER

A material delivery extension reduces leaking/spilling during transport and leads into the patented pre-wet mixing chamber. It also provides a cab-forward design for added stability.

COMMON PART CHUTE DESIGN

The ergonomic, hinged design uses fewer components for all models, making service easy. A direct drive motor offers better torque and reduces servicing.

STAND ON END

Special design allows the hopper to stand on end for easier storage in the off-season. This also allows easier installation into the truck bed.

MATERIAL SPILL PROTECTOR

CHAIN MODELS ONLY

A protection flap at the end of the conveyor prevents material from spilling out and pooling near the vehicle cab.



HOPPER GEOMETRY

The molded polyethylene tub geometry is optimized for better material flow. This allows for a smoother, even flow that prevents materials from getting stuck.



ACCESSORIES

Strobe | Work Light | Secondary Work Light | Vibrator
Inverted V (opt chain models, std on auger models)
Rearview Material Monitoring Camera | Central Point Grease
Tri-Shield Defense Pre-Wet & Direct Liquid Application

MORE JOBS. DONE FASTER.



MARAUDER™ POLYETHYLENE HOPPERS

	P150C	P220C	P150A	P220A
Body Side Length	7' (213.4 cm)	8' (243.9 cm)	7' (213.4 cm)	8' (243.9 cm)
Capacity – Volume	1.5 cu yd (1.15 cu m)	2.2 cu yd (1.68 cu m)	1.5 cu yd (1.15 cu m)	2.2 cu yd (1.68 cu m)
Capacity – Weight*	3,240 lb (1469.6 kg)	4,752 lb (2155.5 kg)	3,240 lb (1469.6 kg)	4,752 lb (2155.5 kg)
Hopper Construction	Polyethylene Body, Stainless Steel Drive line			
Recommended Bed Length	74" (188 cm)	90" (228.6 cm)	74" (188 cm)	90" (228.6 cm)
Approx. Weight – Empty	723 lb (328 kg)	823 lb (373.3)	673 lb (305.3 kg)	793 lb (360 kg)
Material Delivery System	Pintle Chain Conveyor System		HELIXX™ Auger Technology	
Conveyor Width	16" (40.6 cm)		N/A	
Conveyor Material	Sand & Salt/Sand Mix		N/A	
HELIXX™ Auger Dimensions	N/A		6" (15.2 cm) Diameter	
Auger Material	N/A		Bulk Rock Salt	
Spinner Size	16" (40.6 cm) diameter			
Salt Spread Width	36' (11 m)		36' (11 m)	
Sand Spread Width	24' (7.3 m)		N/A	
Vehicle Application	Pickup	Pickup, Flatbed/Dump Body	Pickup	Pickup, Flatbed/Dump Body

DIMENSIONS – Refer to the schematics below

A.	Hopper Length	96.50" (245.1 cm)	104.50" (265.4 cm)	96.50" (245.1 cm)	104.50" (265.4 cm)
B.	Length from Cab Side to Second Leg	80.00" (203.2 cm)	87.00" (221 cm)	80.00" (203.2 cm)	87.00" (221 cm)
C.	Overall Hopper Length	108.25" (275 cm)	116.25" (295.3 cm)	108.25" (275 cm)	116.25" (295.3 cm)
D.	Width of Hopper Opening	63.50" (161.3 cm)	63.50" (161.3 cm)	63.50" (161.3 cm)	63.50" (161.3 cm)
E.	Height of Hopper w/o Chute	46.00" (116.8 cm)	51.50" (130.8 cm)	46.00" (116.8 cm)	51.50" (130.8 cm)

* Material weight equates to approximately 2,160 lb/yard³ or 80 lb/ft³ (1 bag rock salt = approx. 1 ft³)

REFERENCE DIAGRAMS
reference diagrams show chain models

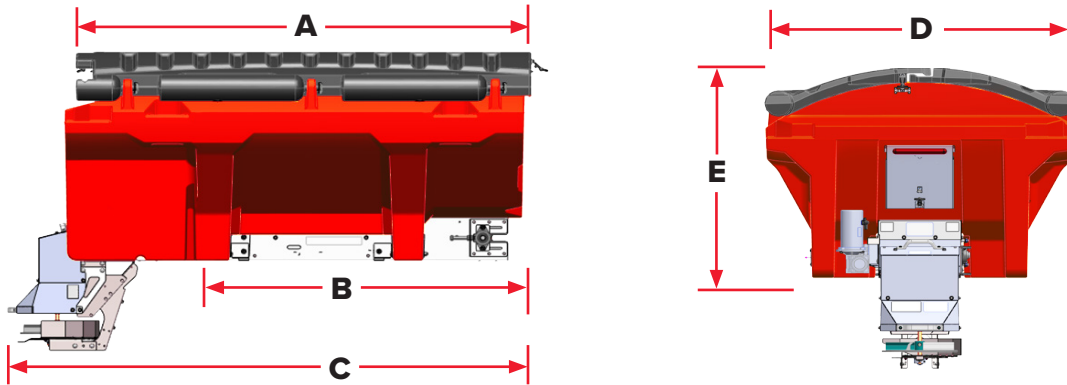

MORE JOBS. **DONE FASTER.**

2 WINTER WARRANTY

Western Products reserves the right under its product improvement policy to change construction or design details and furnish equipment when so altered without reference to illustrations or specifications used. Western Products or the vehicle manufacturer may require or recommend optional equipment for spreaders. Do not exceed vehicle ratings. This product is manufactured under the following patents US: 7,481,384; 11,608,379; other patents pending. Western Products offers a limited warranty for all hopper spreaders and accessories. See separately printed page for this important information. The following are registered (®) or unregistered (™) trademarks of Douglas Dynamics, LLC: HELIXX™, MARAUDER™, WESTERN®.